

Ground Stacking:

6. The FB100 Ground Stack Foot Kit:

The FB100 Flybar requires the use of a supplied Ground Stack Foot Kit to ground stack DRM12A loudspeakers. This kit is made up of the following parts:

FB100 Flybar Ground Stack Foot Kit contents:

Item	Quantity	Description
A	1	Assembly Bracket Foot FB100
B	2	Screw 6 M x 30 mm Lg
C	2	Locking washer 6 M

Required Tools (not included):

4 mm hex key

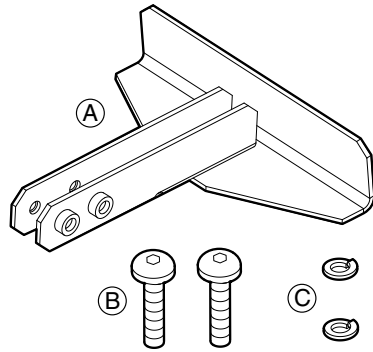

7. Attaching the Ground Stack Foot to the FB100 Flybar:

The Ground Stack Foot is mounted to the underside of the FB100 Flybar. The flybar is correctly oriented when the hole numbers are right side up and the flybar's fixed latches point down. The latches serve as additional feet in a ground stack application.

- With the edge of the foot facing front, fit the two (2) arms of the foot on each side of the flybar.
- Align the two (2) holes in the foot to the holes in the flybar.
- Insert both screws with their lock washers through the holes in the foot and flybar. Then thread the screws into the internal nuts on the second arm of the foot.
- Tighten the two (2) screws using the 4 mm hex key.

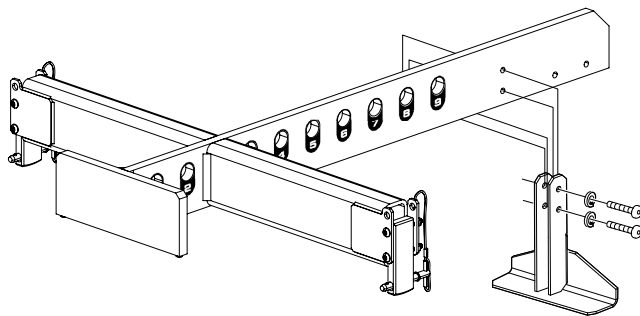

LOUD Audio, LLC.
16220 Wood-Red Road NE
Woodinville, WA 98072
800/258-6883 • FAX 425/487-4337

Part No. 2051268 Rev B 12/18
© 2018 LOUD Audio, LLC. All Rights Reserved.

8. Ground stacking DRM12A loudspeakers on the FB100 Flybar:

A maximum of three (3) DRM12A loudspeakers may be stacked and locked on an FB100 Flybar. Only one (1) person is required to stack the first two (2) DRM12A loudspeakers on the flybar.

a. Position an DRM12A loudspeaker on the flybar so its two (2) side rigging tubes are aligned above the fixed latches in the flybar.

b. Remove the two (2) side quick release pins from the flybar. They may be inserted in the latch through holes for storage.

c. Remove the two (2) side quick release pins from the sides of the DRM12A loudspeaker; the latches will drop and rest atop the flybar's fixed latches.

d. Align the holes in the DRM12A's latches and the holes immediately above the flybar's latches. Lock the loudspeaker in position by fully inserting the quick release pins removed in the preceding step.

e. Stack additional DRM12A loudspeakers as required. Note that the DRM12A only has two (2) rigging tubes and latches. This procedure is similar to those outlined in sections 3b through 3d.

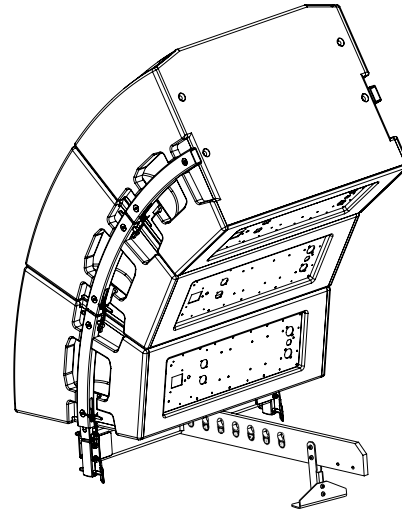

9. Ground stacking an DRM12A / DRM18S loudspeaker array:

The FB100 Flybar is not required for this application, as the DRM18S (with the Flyware Kit, part number 2051056) is used as the ground stack base.

A limit of three (3) DRM12A loudspeakers may be stacked on up to two (2) DRM18S subwoofers. Two (2) people are required to lift and stack the loudspeakers in a mixed array. Loudspeaker stacking and locking procedures outlined in sections 3a through 3d in these instructions should be followed.

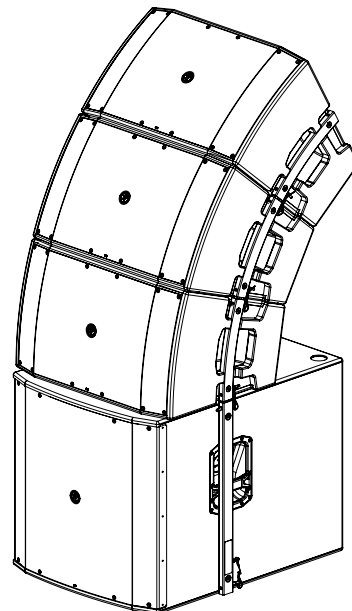

Disclaimer:

LOUD Audio, LLC continually engages in research related to product improvement. New material, production methods, and design refinements are introduced into existing products without notice as a routine expression of that philosophy. For this reason, any current LOUD Audio, LLC product may differ in some respect from its published description, but will always equal or exceed the original design specifications unless otherwise stated.

FB100 Flyware Kit Installation & Rigging Instructions



WARNING: Installation should only be done by experienced licensed professionals. Improper installation may result in damage to the equipment, injury or death. Make sure the loudspeakers are installed in a stable and secure way in order to avoid any conditions that may be dangerous for persons or structures.

Before suspending the loudspeaker(s), make all of the necessary calculations to ensure that all of the components are used within their nominal work load range. Remember that the weakest component determines the safety level of the entire installation.

Introduction

DRM12A and DRM18S loudspeakers may be suspended below a hoisted FB100 Flybar. The flybar is also used as a base for DRM12A loudspeakers when arrayed on the floor. The DRM18S is placed directly on the floor with no need for the FB100 Flybar.

These instructions will first explain how to suspend loudspeakers from the FB100 Flybar, then explain how to use the flybar as a base on which to stack an DRM12A array. Note that a foot assembly must be attached to the flybar before using the FB100 Flybar as a ground stack base. Installation is explained in the second half of these instructions.

Before installing and using this product, please read these instructions carefully and keep them on hand for future reference. Additionally, refer to the product manual(s) for detailed product-specific information. Failure to follow the precautions in these documents may result in injury or damage to the loudspeaker, the FB100 Flybar, or even you!

FB100 Flybar Kit (Part No. 2050041) contents:

Item	Quantity	Description
A	1	FB100 Flybar
B	1	Ground Stack Foot Kit

Required Accessories (not included):

Flyware Kit, part number 2051056
(one per DRM18S subwoofer)

Required Tools (not included):

4 mm hex key
10 mm (or small adjustable) wrench

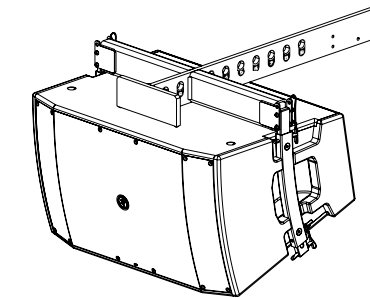

DRM12A loudspeaker
suspended from the FB100
Flybar

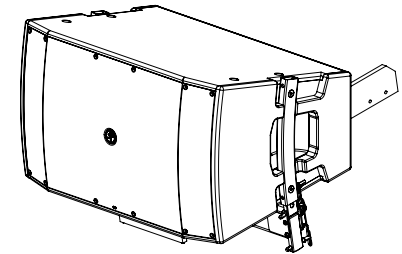

DRM12A loudspeaker
ground stacked on the
FB100 Flybar



WARNING: Two (2) DRM18Ss and four (4) DRM12As in succession suspended by the FB100 Flybar have been tested to a Working Load Limit (WLL) of 452 lb / 205 kg with a design factor of 10:1. Never apply a load that exceeds the WLL.



WARNING: Four (4) DRM12As in succession suspended by the FB100 Flybar have been tested to a Working Load Limit (WLL) of 248 lb / 112 kg with a design factor of 10:1. Never apply a load that exceeds the WLL.

One (1) FB100 Flybar weighs 27 lb / 12.2 kg.
One (1) DRM18S weighs 102 lb / 46.3 kg.
One (1) DRM12A weighs 62 lb / 28.1 kg.

Suspending DRM18S and DRM12A Loudspeakers

Combinations of DRM18S and DRM12A loudspeakers may be suspended in the same array. When doing so, DRM18S(s) are always suspended above DRM12A(s). Therefore, the DRM18S is attached to the FB100 Flybar first.

Remember that a maximum of two (2) DRM18Ss and four (4) DRM12As may be attached to a suspended FB100 Flybar.

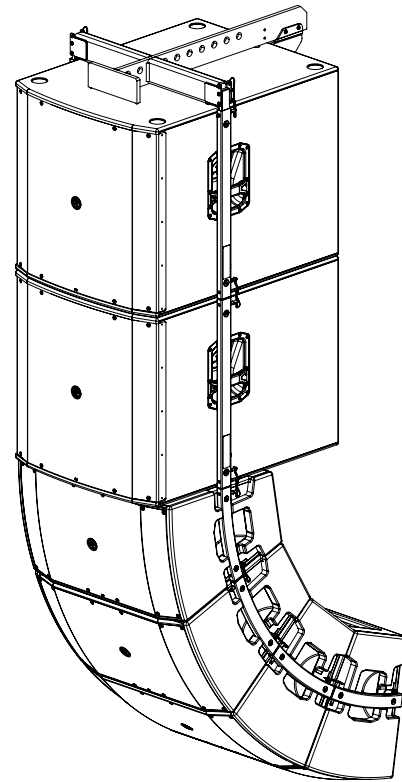

1. Positioning a Flybar Shackle:

The Flybar is suspended by a user-supplied shackle. Its position on the flybar's numbered center bar is determined by the required Array Configuration and aiming angle.

2. Attaching the shackle and hoist cable:

A user-supplied screw pin anchor shackle or safety bolt anchor shackle is used to affix a hoist motor and/or cable to the flybar. Allowable shackle sizes are:

- Minimum: 0.75 T, 9 mm / 0.31 in
- Maximum: 3.25 T, 16 mm / 0.63 in

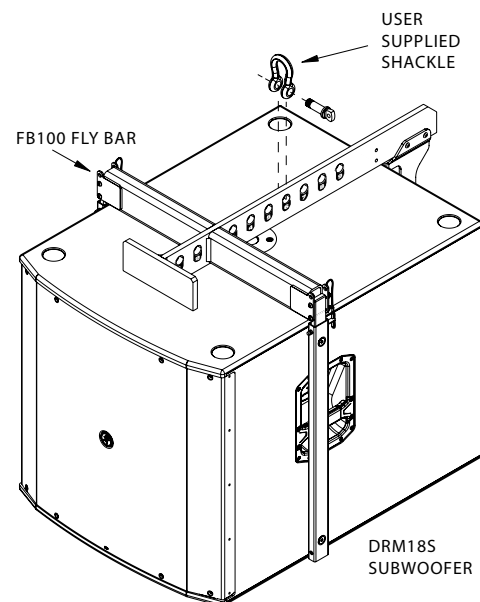

3. Suspending DRM18S Arrays:

At least two (2) people are required to lift, stack and ready DRM18S subwoofers for suspension from the FB100 Flybar.

- a. Place a DRM18S subwoofer on the floor or similar stable surface below the desired rigging point.
- b. Install the Rigging Kit on each DRM18S subwoofer as described in the document that accompanied the kit.
- c. Stack an additional DRM18S subwoofer, if desired.
- d. Each DRM18S subwoofer has latches stored at the bottom of the two (2) rigging tubes. These latches are held in their stored position by quick release pins. When using two subwoofers in the array, remove the two (2) pins of the top subwoofer. The latches will release and slide into the two (2) tubes of the subwoofer below them. Align the holes in the tubes to those in the latches and lock them together by fully inserting the quick release pins.

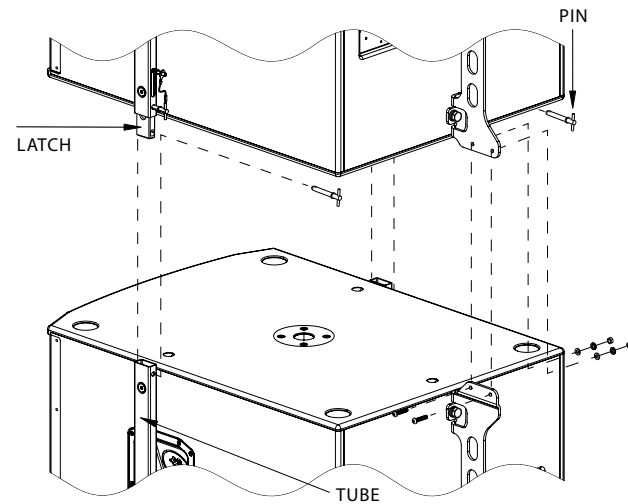

- e. Remove the FB100 Flybar's quick release pins and insert its front two fixed latches into the top DRM18S's rigging tubes. Align the holes in the tubes to those in the latches and lock them together by fully inserting the quick release pins.

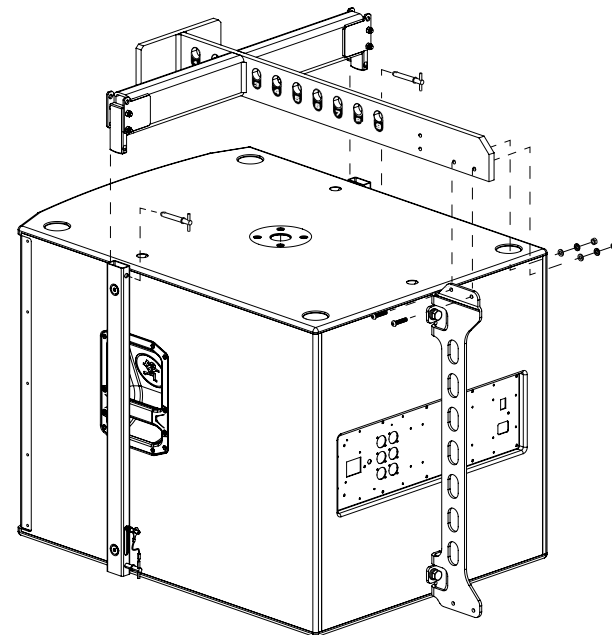

- f. Attach the rear bracket (previously assembled to the DRM18S subwoofer as part of the Rigging Kit) to the back of the flybar with M6 screws (A), flat washers (B), lock washers (C) and hex nuts (D) provided in the Rigging Kit, as shown below. If a second DRM18S subwoofer is suspended, the rear brace on that subwoofer should be attached to the bottom of the rear brace on the DRM18S above, also using the hardware supplied in the Rigging Kit. Tighten all screws using the 4 mm hex key and 10 mm (or small adjustable) wrench.

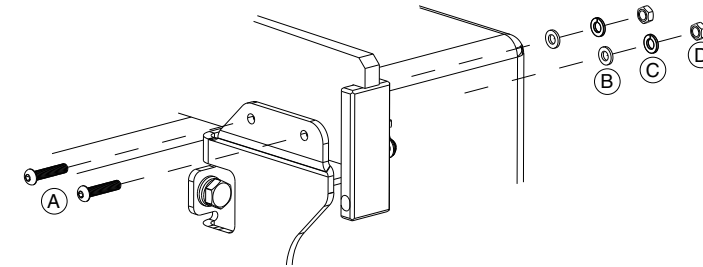

- g. Hoist the array to the desired trim height or to the working height needed for the next applicable procedure.

4. Attaching DRM12A loudspeakers to a suspended DRM18S subwoofer:

At least two (2) people are required to lift and attach an DRM12A loudspeaker to a suspended DRM18S subwoofer.

- a. The two (2) side latches on the bottom suspended DRM18S subwoofer must be lowered from their stored position. Do this by removing the two (2) bottom quick release pins; the latches will drop to their ready position. The bottom rear latch should remain pinned in its stored position.
- b. Lift and position the DRM12A loudspeaker so its rigging tubes capture the two (2) side latches of the DRM18S subwoofer. Align the holes in the tubes to those in the latches and lock them together by fully inserting the quick release pins.
- c. Repeat steps 4a and 4b for any additional DRM12A loudspeakers to be added to the array.

- d. Hoist the array to the desired trim height.

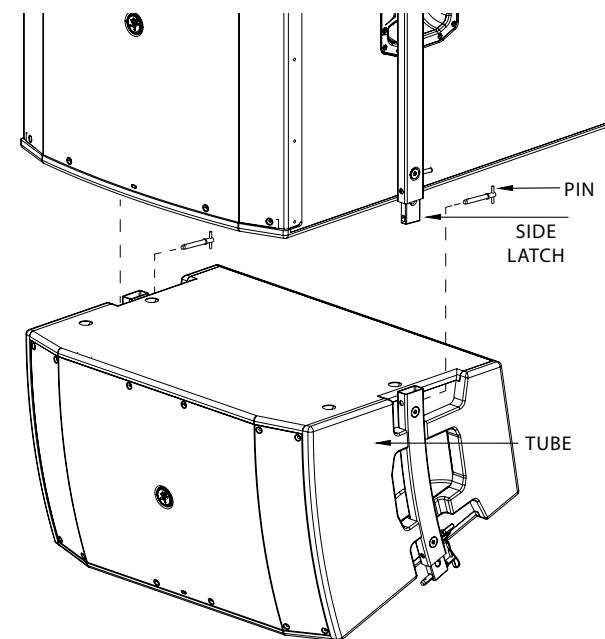

5. Attaching DRM12A loudspeakers to the FB100 Flybar:

Only one (1) person is required to suspend the first two (2) DRM12A loudspeakers from the FB100 Flybar. If a third (3) or fourth (4) DRM12A loudspeaker is to be suspended, then two (2) people are required to lift and attach those.

- a. Attach a lifting apparatus to the FB100 Flybar at the desired rigging point and hoist the flybar above head height.
- b. Stack and lock together up to two (2) DRM12A loudspeakers on the floor or similar stable surface below the flybar. This procedure is similar to those outlined in sections 3b through 3d.
- c. Lower and position the FB100 Flybar. Remove the flybar's two (2) side quick release pins and insert its two (2) fixed latches into the rigging tubes of the top DRM12A loudspeaker. Align the holes in the tubes to those in the latches and lock them together by fully inserting the quick release pins.

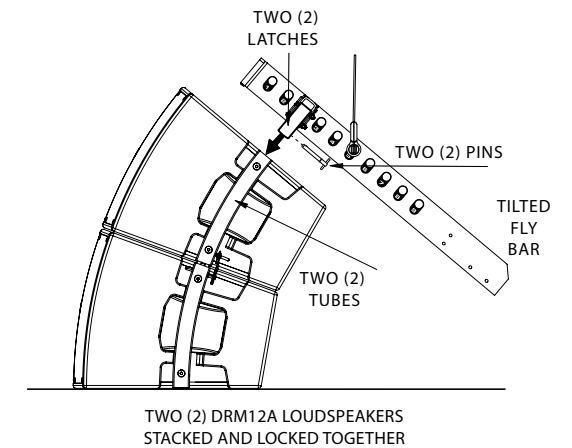

- d. Hoist the array to the desired trim height.

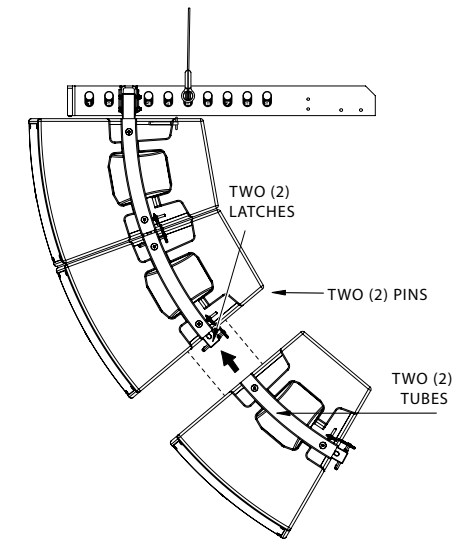

If a third (3) or fourth (4) DRM12A loudspeaker is added, they must be individually lifted and locked to the bottom of the array by two (2) people. This procedure is similar to those outlined in sections 4a through 4c.